

# POWERFLEX®

## PART NUMBER

# PFR85-610

## DESCRIPTION

## REAR BEAM MOUNTING BUSH

## INSTALLATION GUIDE

### Contents (parts per pack):

2 x Polyurethane Bushes    1 x PTFE/Silicone Grease  
2 x Stainless Steel Sleeves

Please read the complete fitting instructions and check package components before fitment. These fitting instructions are to be used as a guide and in conjunction with workshop manual.

It is recommended that:

- all work to be carried out by a licensed technician;
- all safety precautions adhered to;
- wheel alignment to be checked and adjusted as required after any suspension work.
- All fasteners must be tensioned to manufacturer's torque settings.

### Fitting Instructions:

1. Lower the rear beam from the mounting brackets and remove the original bush, taking note of which direction the original bush is fitted.

*NB. If possible, do not loosen/remove the chassis mounted brackets when removing the rear beam.*

2. Clean away any dirt and corrosion from the beam, using a rounded file to remove any sharp edges to prevent damaging the new bush.

3. Press the Powerflex bush into the vacant hole until flush with the beam, matching the orientation of the original bush.

4. OE part numbers starting 6R0 are inserted from the outside of the beam, and parts starting with 1J0 are inserted from the inside.

5. Apply some of the supplied grease to the bore of the Powerflex bush and insert the stainless steel sleeve.

6. Refit the beam to the vehicle and tighten all fasteners to the manufacturer's recommended torque settings.

7. After installation, check the total toe setting of the rear axle and align if necessary, especially if the mounting brackets have been loosened/removed.

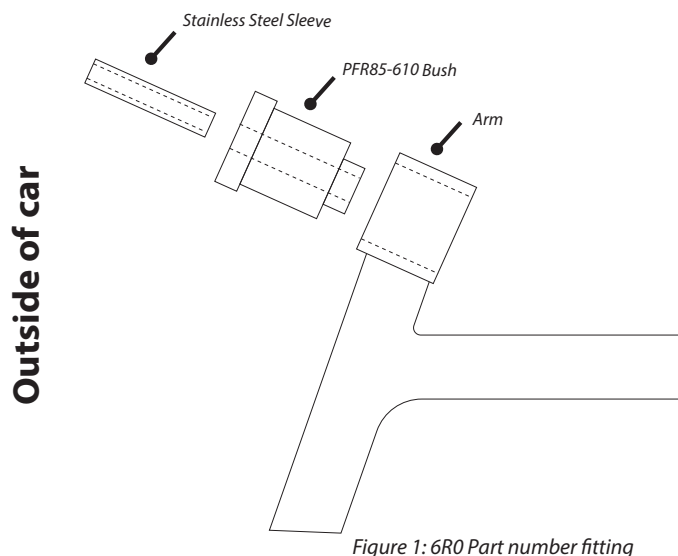

Figure 1: 6R0 Part number fitting

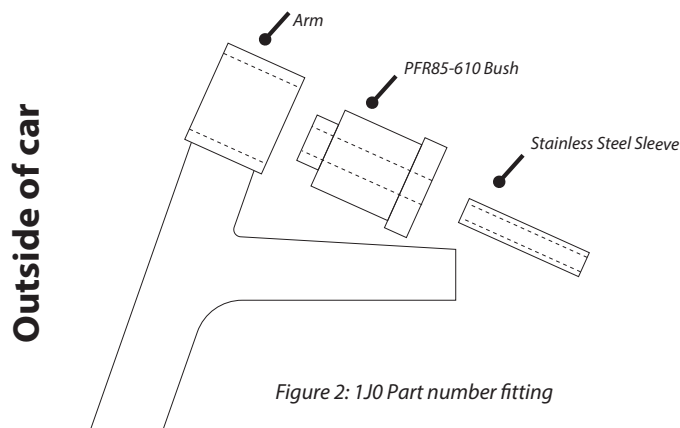

Figure 2: 1J0 Part number fitting