

POWERFLEX®

PART NUMBER

PFR12-610

DESCRIPTION

REAR BEAM MOUNTING BUSH

INSTALLATION GUIDE

Contents (parts per pack):

2 x Polyurethane Bushes 1 x PTFE/Silicone Grease
2 x Stainless Steel Sleeves

Please read the complete fitting instructions and check package components before fitment. These fitting instructions are to be used as a guide and in conjunction with workshop manual.

It is recommended that:

- all work to be carried out by a licensed technician;*
- all safety precautions adhered to;*
- wheel alignment to be checked and adjusted as required after any suspension work.*
- All fasteners must be tensioned to manufacturer's torque settings.*

Fitting Instructions:

1. Remove the original bush from the rear beam mount.
2. Clean any dirt and corrosion from the bore in the arm. Remove any sharp edges from the bore of the rear beam mount.
3. Insert bushes into arm with larger diameter lip facing towards centre of car.
4. Apply some of the supplied grease to the bores of the bushes.
5. Fit the stainless steel sleeve into the bush.
6. The original washers **MUST BE RETAINED** and should be fitted to the outside of the top hats on the larger lip face on the inner side of the bracket to support the bush. (See figure 1)
7. Refit rear bush mount and tension all hardware to manufacturers recommended torque settings.

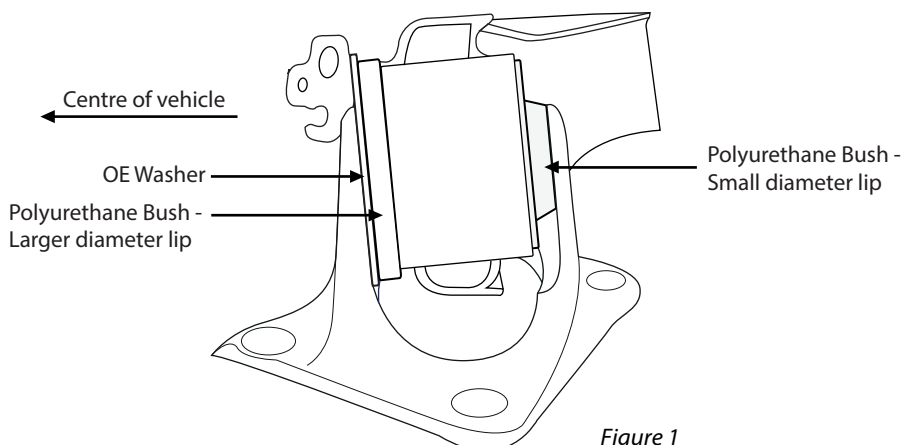

Figure 1