



PART NUMBER

**PFF75K-502**

DESCRIPTION

**FRONT LOWER AFT LINK**

**INSTALLATION GUIDE**

**Contents (parts per pack):**

- 2x Arms Fitted With Bushes
- 1 x PTFE/Silicone Grease
- 4 x Zinc Plated Mild Steel Washers
- 2 x Stainless Steel Sleeves

Please read the complete fitting instructions and check package components before fitment. These fitting instructions are to be used as a guide and in conjunction with workshop manual.

It is recommended that:

- all work to be carried out by a licensed technician;
- all safety precautions adhered to;
- wheel alignment to be checked and adjusted as required after any suspension work.
- All fasteners must be tensioned to manufacturer's torque settings.



**Fitting Instructions:**

1. Apply the supplied grease to the knurled bore and end faces of the polyurethane bushes.
2. Insert the stainless steel sleeves until flush with the bush end faces.
3. Place a mild steel washer on both faces of the bush.
4. Refit the arm to the vehicle and tension all hardware to manufacturers recommended torque settings.



Mild Steel Washer

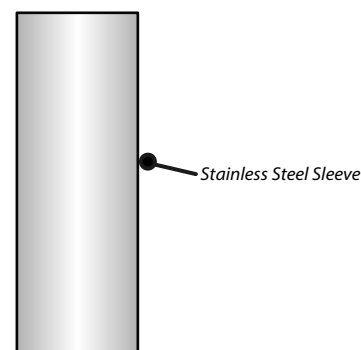

Stainless Steel Sleeve

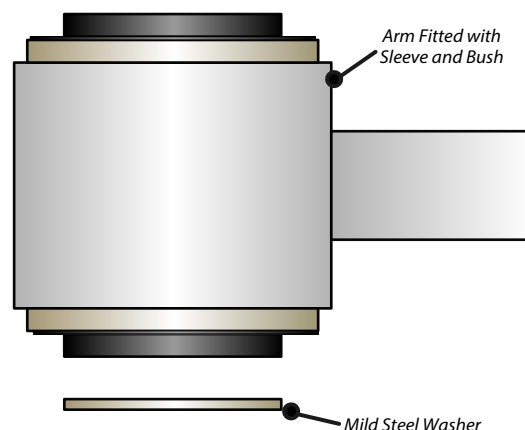

Arm Fitted with Sleeve and Bush

Mild Steel Washer

Figure 1