

POWERFLEX®

PART NUMBER

PFF60-701G

DESCRIPTION

FRONT ARM FRONT BUSH CAMBER ADJUSTABLE

INSTALLATION GUIDE

Contents (parts per pack):

- | | |
|------------------------------|------------------------------------|
| 2 x Polyurethane Bushes | 1 x PTFE/Silicone Grease |
| 2 x Stainless Steel Sleeves | 2 x Zinc Plated Mild Steel Washers |
| 4 x Zinc Plated Outer Shells | 1 x Spanner |

Please read the complete fitting instructions and check package components before fitment. These fitting instructions are to be used as a guide and in conjunction with workshop manual.

It is recommended that:

- all work to be carried out by a licensed technician;
- all safety precautions adhered to;
- wheel alignment to be checked and adjusted as required after any suspension work.
- All fasteners must be tensioned to manufacturer's torque settings.

Fitting Instructions:

1. Remove the original rubber bush from the arm including the outer shell.
2. Clean any dirt and corrosion from the bore of the arm, removing any sharp edges or burrs with a rounded file.
3. Press the outer shells into either side of the arm as shown in Fig1.
4. Press the Powerflex bush into the arm so that the flanges of the bush protrude on each side of the fitted shells.

Tip: If you are having trouble pressing the bush in, try pressing the bush in at a slight angle so that one part of the lip is already in the bore of the shell, and when steady pressure is applied, the rest of the lip should follow.

5. Apply some of the supplied grease to the bore of the bush and press in the stainless steel sleeve with the adjustable head sitting up against the lower face of the bush as shown in Fig 1/2.

6. Place the supplied washer on the exposed end of the sleeve on the upper face of the bush and refit the arm to the subframe of the car as shown in Fig 1/2.

7. For maximum camber, rotate the sleeve with the supplied spanner so that the bore is positioned as shown in Fig 3.

8. Tighten all fasteners to the manufacturer's recommended torque settings.

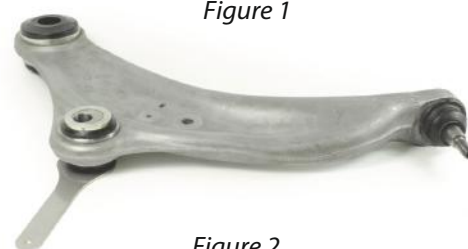
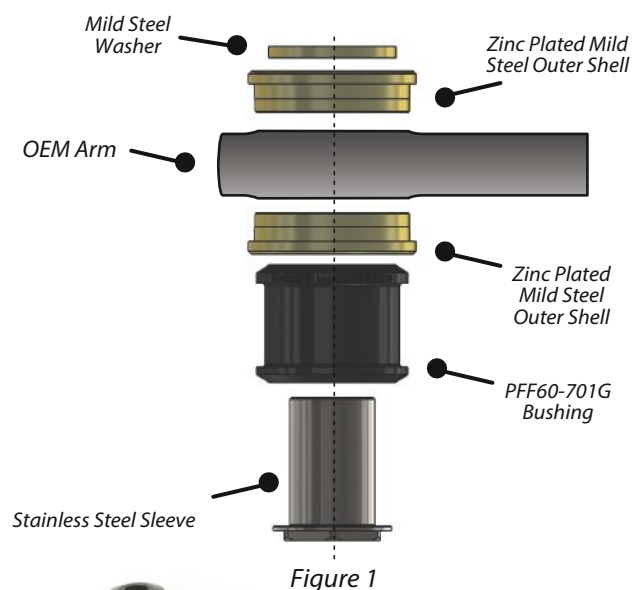

Offset Hole for Adjustable Camber
Camber Degree Increase

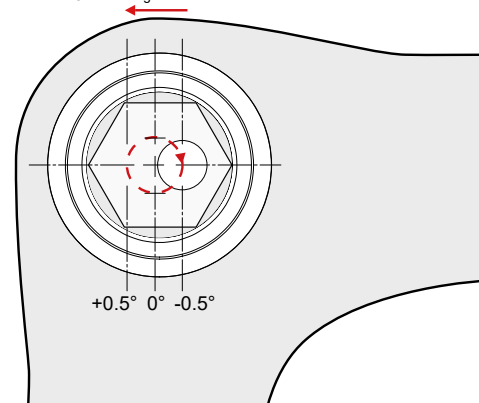

Figure 3