

POWERFLEX®

PART NUMBER

PFF60-1001G

DESCRIPTION

FRONT WISHBONE BUSHES ADJUSTABLE

INSTALLATION GUIDE

Contents (parts per pack):

8 x Polyurethane Bushes	4 x Zinc Plated Outer Shells
4 x Stainless Steel Sleeves	1 x PTFE/Silicone Grease
1 x C45 Spanner	4 x Zinc Plated Washers

Please read the complete fitting instructions and check package components before fitment. These fitting instructions are to be used as a guide and in conjunction with workshop manual.

It is recommended that:

- all work to be carried out by a licensed technician;
- all safety precautions adhered to;
- wheel alignment to be checked and adjusted as required after any suspension work.
- All fasteners must be tensioned to manufacturer's torque settings.

Fitting Instructions:

1. Remove the original bush from the arm.
2. Clean any dirt or burrs from the bore in the arm. Remove any sharp edges with a rounded file.
3. Press in the Zinc Plated Outer Shell into the arm from the inside of the arm out, as shown in figure 1.
4. Press a top hat bush from either side of the outer shell as shown in figure 1.
5. Apply the supplied grease to the bore and the mounting faces of each bush.
6. Fit the Stainless-Steel sleeve into the bushes with the adjustable part on the outside of the arm, shown in figure 1.
7. Fit the washer to the opposing end of the stainless steel sleeve.
8. Use the included spanner to rotate the sleeve to provide a range of camber to the wheels see figure 2.
9. Refit the arm and tension all hardware to manufacturers recommended torque settings.

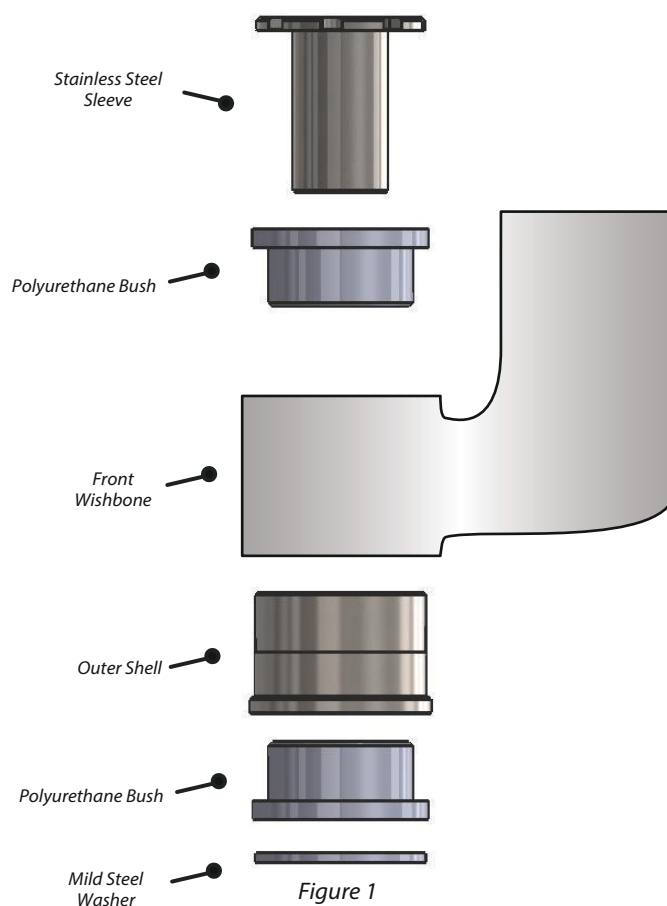

Figure 1

Offset Hole for Adjustable Camber

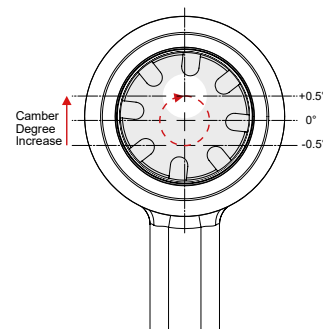

Figure 2