

POWERFLEX®

PART NUMBER

PFF57-203

DESCRIPTION

FRONT WISHBONE REAR BUSH

INSTALLATION GUIDE

Contents (parts per pack):

4 x Polyurethane Bushes 1 x PTFE/Silicone Grease
2 x Stainless Steel Sleeves 2 x Mild Steel Washers

Please read the complete fitting instructions and check package components before fitment. These fitting instructions are to be used as a guide and in conjunction with workshop manual.

It is recommended that:

- all work to be carried out by a licensed technician;*
- all safety precautions adhered to;*
- wheel alignment to be checked and adjusted as required after any suspension work.*
- All fasteners must be tensioned to manufacturer's torque settings.*



Fitting Instructions:

1. Remove the original bush from the wishbone including its outer shell.
2. Clean any dirt or corrosion from the bore of the arm, using a rounded file to remove any sharp edges.
3. Place the washer with the larger bore on the wishbone pin first, and let it sit flush with the arm at the base of the pin.
4. Insert the two polyurethane bushes into the vacant hole of the bracket until flush.
5. Insert the sleeve into the void of the polyurethane bushes and line up the bore of the sleeve with the pin.
6. Fit the washer with the smaller bore onto the end of the assembly followed by refitting the original nut and washer.
7. Tension all hardware to manufacturers recommended torque settings.

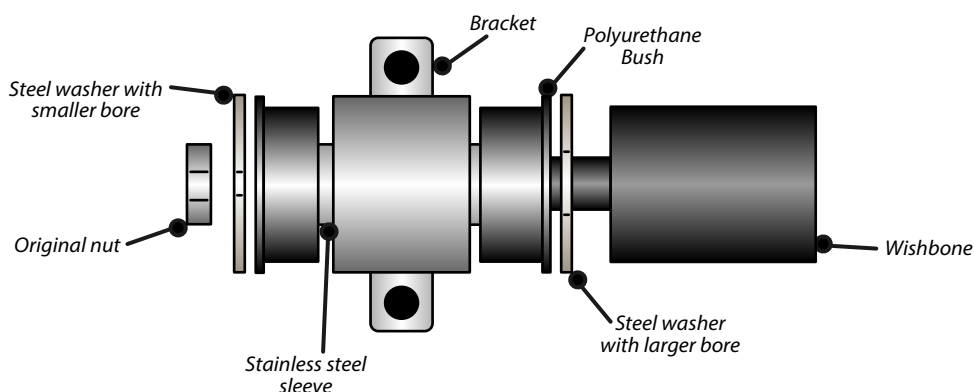

Figure 1