



PART NUMBER

PFF5-301

DESCRIPTION

FRONT LOWER WISHBONE REAR (CONCENTRIC)

INSTALLATION GUIDE

Contents (parts per pack):

- 2 x Polyurethane A Bushes
- 1 x PTFE/Silicone Grease
- 2 x Polyurethane B Bushes
- 2 x Mild Steel Washers

Please read the complete fitting instructions and check package components before fitment. These fitting instructions are to be used as a guide and in conjunction with workshop manual.

It is recommended that:

- all work to be carried out by a licensed technician;*
- all safety precautions adhered to;*
- wheel alignment to be checked and adjusted as required after any suspension work.*
- All fasteners must be tensioned to manufacturer's torque settings.*

Fitting Instructions:

1. Remove the original rear bush from the front arm and remove the original bush from the bracket.
2. Clean any dirt and corrosion from the bracket and file off any sharp edges.
3. Push polyurethane part B into the bracket with the larger diameter facing the front of the car and the arm.
4. Place the washer onto the pin of the arm and push polyurethane part A onto the pin of the arm, making sure it is pushed all the way in.
5. Apply some of the supplied grease into the bore of polyurethane part B and the outside of the part A.
6. Push the bracket assembly onto polyurethane part A on the arm until part A sits flush inside part B.
7. Refit the front arm to the vehicle and tension all hardware to manufacturers recommended torque settings.

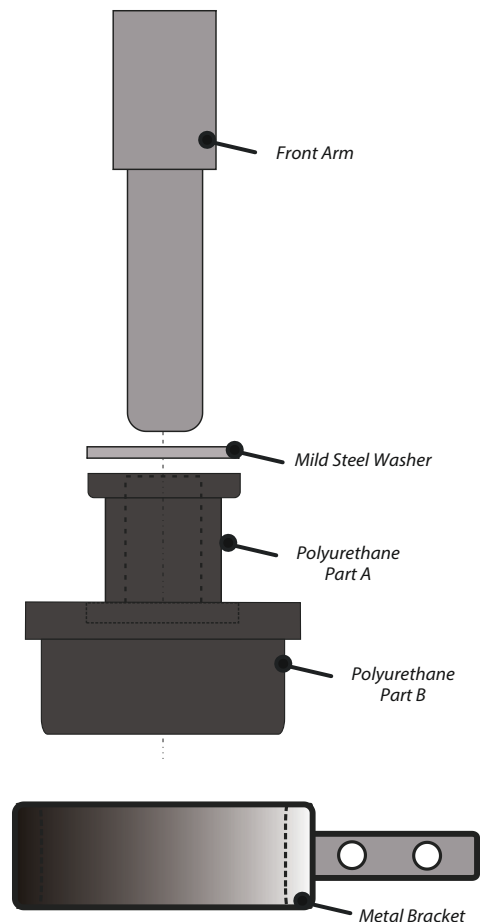

Figure 1