

# POWERFLEX®

## PART NUMBER

# PFF5-2301G

## DESCRIPTION

## FRONT RADIUS ARM BUSH CASTER ADJ

## INSTALLATION GUIDE

### Contents (parts per pack):

2 x Polyurethane Bushes	1 x PTFE/Silicone Grease
2 x Stainless Steel Sleeves	2 x Zinc Plated Mild Steel Washers
4 x Outer Shells	2 x Nylon Washers
1 x 34AF Spanner	

Please read the complete fitting instructions and check package components before fitment. These fitting instructions are to be used as a guide and in conjunction with workshop manual.

It is recommended that:

- all work to be carried out by a licensed technician;
- all safety precautions adhered to;
- wheel alignment to be checked and adjusted as required after any suspension work.
- All fasteners must be tensioned to manufacturer's torque settings.



### Fitting Instructions:

1. Remove the original bush including its outer shell from the arm.
2. Clean any dirt or burrs from the bore in the arm. Remove any sharp edges with a rounded file.
3. Press the outer shells into each side of the arm, until sitting flush to the face of the arm.
4. Apply some washing up liquid to the bore of the shells and press the polyurethane bush in until fully through the arm. The wider top hat should be facing outwards in the direction of the wheel as shown in Fig. 1

**Tip: If you are having trouble pressing the bush in, try pressing the bush in at a slight angle so that one part of the lip is already in the bore of the shell, and when steady pressure is applied, the rest of the lip should follow.**

5. Apply some of the supplied grease to the bore of the bush, fit the plated washer to the adjustable sleeve and insert the sleeve into the bush from the inside of the vehicle.

6. For maximum caster, use the supplied spanner to rotate the sleeve so that the bore is positioned facing down the length of the arm as shown in Fig. 2

7. Refit the arm to the vehicle and tension all hardware to manufacturers recommended torque settings. Check alignment and adjust as necessary.

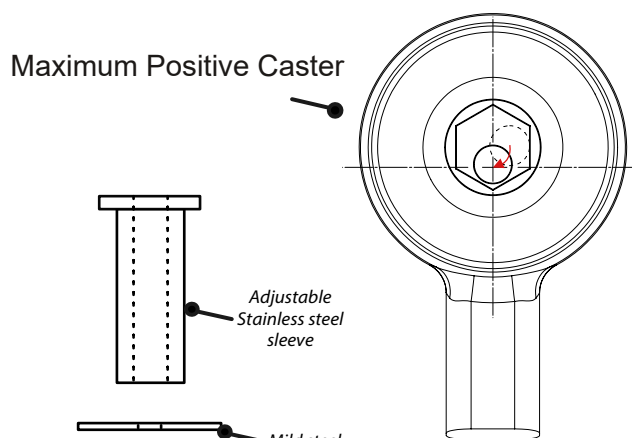

Figure 2

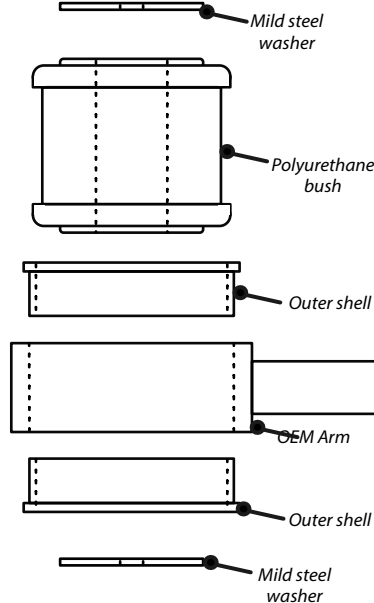

Figure 1