

# POWERFLEX®

## PART NUMBER

# PFF5-1902G

## DESCRIPTION

## FRONT CONTROL ARM TO CHASSIS BUSH

## INSTALLATION GUIDE

### Contents (parts per pack):

2 x Polyurethane Bushes      1 x PTFE/Silicone Grease

2 x Stainless Steel Sleeves      1 x Spanner

4 x Zinc Plated Mild Steel Outer Shells

Please read the complete fitting instructions and check package components before fitment. These fitting instructions are to be used as a guide and in conjunction with workshop manual.

It is recommended that:

- all work to be carried out by a licensed technician;
- all safety precautions adhered to;
- wheel alignment to be checked and adjusted as required after any suspension work.
- All fasteners must be tensioned to manufacturer's torque settings.

### Fitting Instructions:

1. Remove the original bush including its outer shell from the arm.
2. Clean any dirt or burrs from the bore in the arm. Remove any sharp edges with a rounded file.
3. Press the plated steel outer shells into each side of the arm, until sitting flush to the face of the arm.
4. Apply some washing up liquid to the bore of the shells and press the polyurethane bush in until fully through the arm.

**Tip: If you are having trouble pressing the bush in, try pressing the bush in at a slight angle so that one part of the lip is already in the bore of the shell, and when steady pressure is applied, the rest of the lip should follow.**

5. Apply the supplied grease to the bore and the mounting faces of each bush.

6. Fit the Stainless-Steel sleeve into the bushes.

7. For maximum camber the spanner to rotate the sleeve so that the bore is positioned as shown in figure 2.

8. Refit the arm and tension all hardware to manufacturers recommended torque settings.

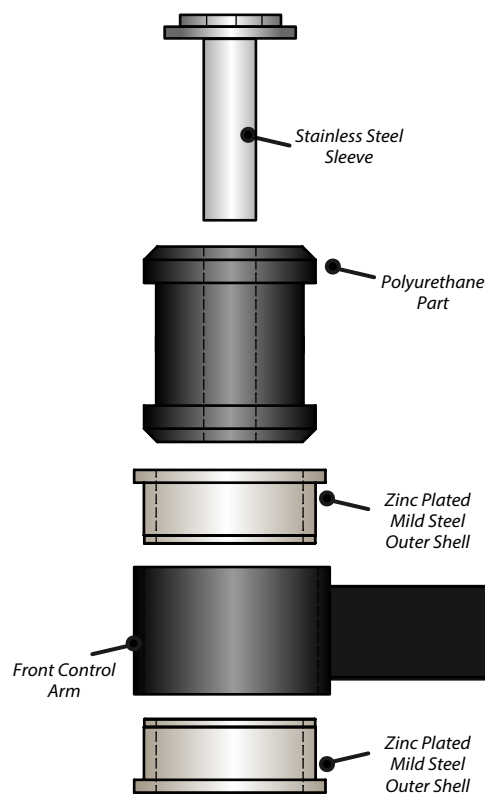

Figure 1

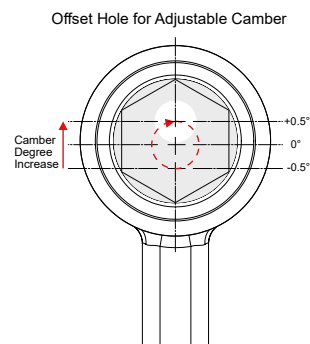

Figure 2