

POWERFLEX®

PART NUMBER

PFF5-101MS

DESCRIPTION

FRONT WISHBONE REAR BUSH SUPPORT KIT

INSTALLATION GUIDE

PFF5-101MS is to provide additional support to PFF5-101

Contents (parts per pack):

2 x Zinc Plated Washers	2 x Shake-proof washers
2 x M14 Mounting Bolts	1 x PTFE/Silicone Grease

Please read the complete fitting instructions and check package components before fitment. These fitting instructions are to be used as a guide and in conjunction with workshop manual.

It is recommended that:

- all work to be carried out by a licensed technician;*
- all safety precautions adhered to;*
- wheel alignment to be checked and adjusted as required after any suspension work.*
- All fasteners must be tensioned to manufacturer's torque settings.*



Fitting Instructions:

1. Assuming this upgrade is being carried out as part of fitting PFF5-101, the front wishbone will already have been removed from the vehicle.
2. Secure the wishbone in a vice and tap the centre of the hexagonal pin on the wishbone using an M14 x 2.00 metric tap. Clean away any dirt or corrosion at this point.
3. Re-fit the wishbone and bracket to the subframe of the vehicle, including our PFF5-101 bush.
4. Fit the supplied spring washer to the bolt, followed by the large plated washer. Apply supplied grease to the end of each bush that will contact the large washer.
5. Fit the bolt to the arm using a small amount of thread lock liquid (not supplied) to help secure the assembly.
6. Tighten the bolt to 112NM or 83 ft-lb. Please do not over tighten.

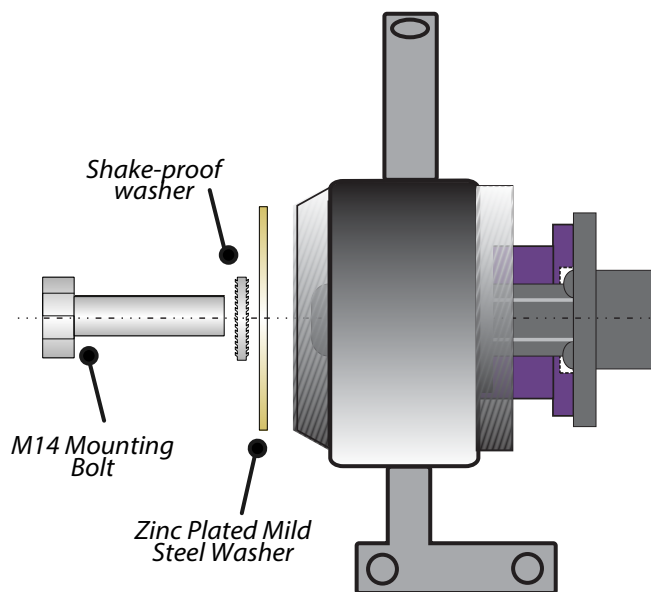

Figure 1



Figure 2