



PART NUMBER

PFF19-1820

DESCRIPTION

LOWER ENGINE MOUNT BUSH

INSTALLATION GUIDE

Product Description:

This part replaces the original bush in bracket OE number: 5165555 and comes with an insert that limits the flexibility of the bush, this can be fitted to further reduce engine movement.

Contents (parts per pack):

- 1 x Polyurethane A bush
- 1 x Polyurethane B bush
- 2 x Polyurethane C inserts (optional)
- 1 x Stainless steel sleeves
- 1 x PTFE / Silicone Assembly Grease

Please read the complete fitting instructions and check package components before fitment. These fitting instructions are to be used as a guide and in conjunction with workshop manual.

It is recommended that:

- all work to be carried out by a licensed technician;
- all safety precautions adhered to;
- wheel alignment to be checked and adjusted as required after any suspension work.

Fitting Instructions:

1. Remove the original bush from the mounting bracket, clean any dirt and corrosion from the bore in the radius arm. Remove all sharp edges using a file.
2. Fit the polyurethane A bush in the upper position of the mounting bracket, aligning the voids in the bush along the length of the bracket.
3. Fit the polyurethane B bush in the lower position of the mounting bracket, aligning the voids in the bush along the length of the bracket.
4. Apply some of the supplied PTFE/ Silicone grease to the bore and mounting faces of each bush and insert the sleeve into the bush.
5. To limit flexibility of the bush, add the optional polyurethane C inserts into the voids in the bush.
6. Re-fit the bracket to the car and tighten all hardware to manufacturers recommended torque settings.

TOP

C Insert
(optional)

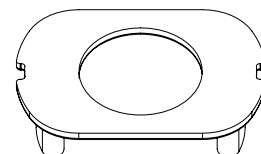

A Bush

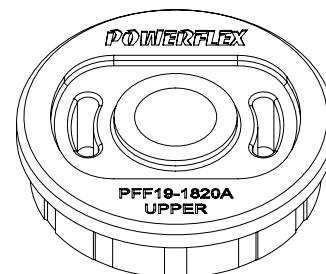

Sleeve

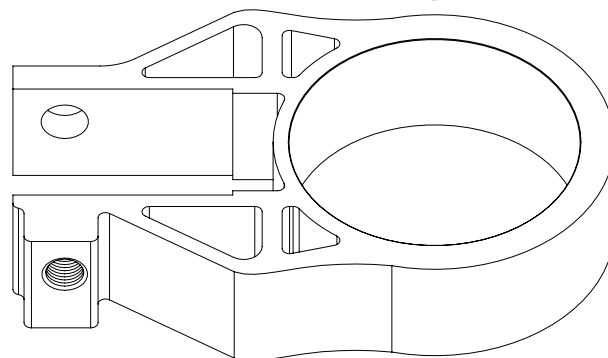
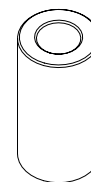

B Bush

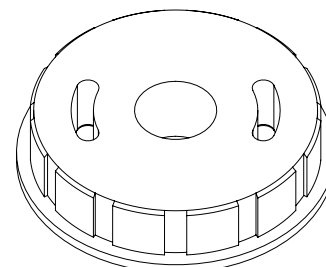

C Insert
(optional)

