

POWERFLEX®

PART NUMBER

PFF16-802

DESCRIPTION

FRONT LOWER ARM REAR BUSH

INSTALLATION GUIDE

Contents (parts per pack):

2 x Polyurethane Bushes 1 x PTFE/Silicone Grease
2 x Stainless Steel Sleeves 2 x Zinc Plated Mild Steel Outer Shell

Please read the complete fitting instructions and check package components before fitment. These fitting instructions are to be used as a guide and in conjunction with workshop manual.

It is recommended that:

- all work to be carried out by a licensed technician;*
- all safety precautions adhered to;*
- wheel alignment to be checked and adjusted as required after any suspension work.*
- All fasteners must be tensioned to manufacturer's torque settings.*



Fitting Instructions:

1. Remove original bush and remove any dirt and corrosion, including filing away any sharp edges.
2. Insert the Zinc Plated Mild Steel Shell, with the brim resting on the top of the arm, ensuring it sits flush.
3. Apply some of the supplied grease to the Polyurethane Bush, and using a workshop press insert the Polyurethane Bush into the bore of the Zinc Plated Mild Steel Outer Shell, ensuring the brim of the Polyurethane Bush is in contact with the outer brims of the Outer Shell.
4. Apply some more of the supplied grease to the outer surface of the Stainless Steel Sleeve, and insert it into the bore of the Polyurethane Bush, ensuring it sits flush within the bore.
5. Refit the arm and tension all hardware to the manufacturer's torque settings

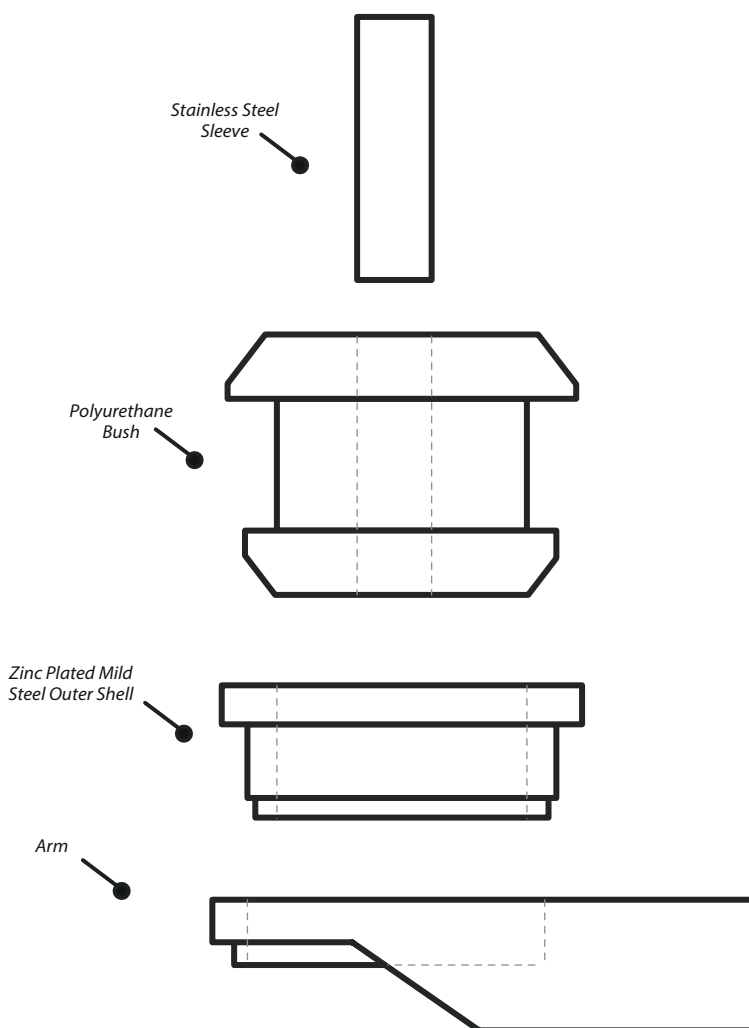

Figure 1