

# POWERFLEX®

## PART NUMBER

# PFF1-1002G

## DESCRIPTION

### FRONT WISHBONE REAR BUSH - CASTER OFFSET

## INSTALLATION GUIDE

### Contents (parts per pack):

2 x Polyurethane Bushes      1 x PTFE/Silicone Grease  
2 x Stainless Steel Sleeves

Please read the complete fitting instructions and check package components before fitment. These fitting instructions are to be used as a guide and in conjunction with workshop manual.

It is recommended that:

- all work to be carried out by a licensed technician;
- all safety precautions adhered to;
- wheel alignment to be checked and adjusted as required after any suspension work.
- All fasteners must be tensioned to manufacturer's torque settings.



### Fitting Instructions:

1. Remove the original bush from the arm.
2. Clean any dirt and corrosion from the bore of the arm and file off any sharp edges.
3. Push in the new polyurethane bush from the top side, as shown in Figure 1. Push the bush in at a slight angle for an easier fitting.

**Tip: Apply some washing up liquid to the bush for ease of fitting.**

4. Apply some of the supplied grease to the bore of the polyurethane bush.
5. Press the stainless steel sleeve into the bore of the bush.
6. For maximum caster adjustment, place the bore of the sleeve towards the middle of the car.
7. Re-fit the arm to the car and tension all hardware to manufacturers recommended torque settings.

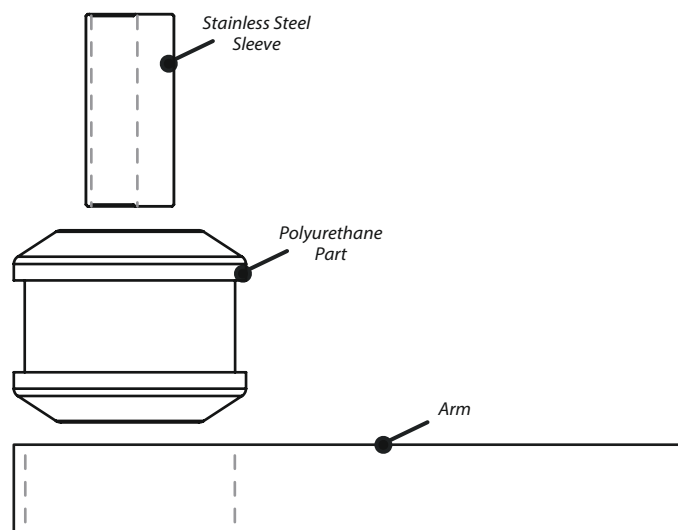

Figure 1

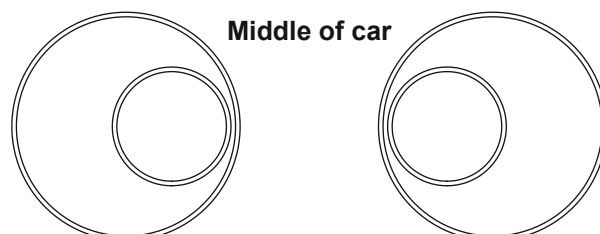

Figure 2 - for maximum caster adjustment