



PART NUMBER
PF85K-1008

DESCRIPTION
GOLF Mk7

Thank You Letter

Many thanks for purchasing this Powerflex Handling Package.

This selection of parts has been put together to give you the perfect combination of value versus performance and based on years of experience, we have selected what we feel are the products that are going to give you the best handling improvements for your vehicle whilst being mindful of cost.

Your Powerflex Handling Package can be fitted to refresh the suspension feel of your vehicle or can be a great accompaniment to other suspension upgrades when preparing a vehicle for track driving.

Below is a listing of the parts included in this kit,

- PFF85-501 - FRONT WISHBONE FRONT BUSH x 2
- PFF85-802 - FRONT WISHBONE REAR BUSH x 2
- PFF85-832 - LOWER ENGINE MOUNT INSERT x 1
- PFR85-816 - REAR TRAILING ARM FRONT BUSH X 2

We hope you enjoy the difference Powerflex suspension bushes make to your vehicle.



POWERFLEX®

PART NUMBER

PFF85-802

DESCRIPTION

FRONT WISHBONE REAR BUSH

INSTALLATION GUIDE

Contents (parts per pack):

- 2 x Polyurethane Bushes
- 1 x PTFE/Silicone Grease
- 2 x Stainless Steel Sleeves
- 2 x Zinc Plated Mild Steel Outer Shells

Please read the complete fitting instructions and check package components before fitment. These fitting instructions are to be used as a guide and in conjunction with workshop manual.

It is recommended that:

- all work to be carried out by a licensed technician;
- all safety precautions adhered to;
- wheel alignment to be checked and adjusted as required after any suspension work.
- All fasteners must be tensioned to manufacturer's torque settings.



Fitting Instructions:

1. Remove the original rubber bush from the front wishbone.
2. Clean any dirt and corrosion from the bore of the arm, and file off any sharp edges.
3. Push the outer shell into the bore, smaller diameter first, from the top of the arm.
4. Push the polyurethane part into the bore of the outer shell, smaller diameter first. **TIP: Apply some washing up liquid around the polyurethane part to aid in fitting.**
5. Apply some of the supplied grease to the bore of the polyurethane part and push the stainless steel sleeve into the bore so it sits flush inside the bush. For maximum caster adjustment, the offset holes in the sleeves must be closest to the middle of the car, as shown in figure 1.
6. Tension all hardware to manufacturers recommended torque settings.

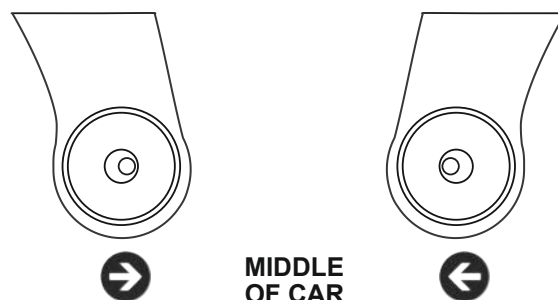

Figure 1

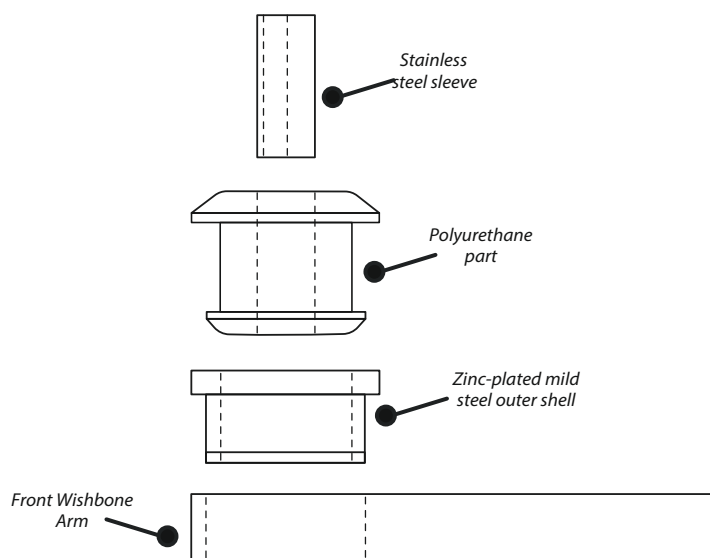

Figure 2



PART NUMBER

PFR85-816

DESCRIPTION

REAR TRAILING ARM FRONT BUSH

INSTALLATION GUIDE

Contents (parts per pack):

- 2 x Polyurethane A Bushes
- 1 x PTFE/Silicone Grease
- 4 x Polyurethane B Bushes
- 2 x Stainless Steel Sleeves

Please read the complete fitting instructions and check package components before fitment. These fitting instructions are to be used as a guide and in conjunction with workshop manual.

It is recommended that:

- all work to be carried out by a licensed technician;
- all safety precautions adhered to;
- wheel alignment to be checked and adjusted as required after any suspension work.
- All fasteners must be tensioned to manufacturer's torque settings.



Fitting Instructions:

1. Remove the rear trailing arm from the car.
2. Remove the original rubber bush from the arm.
3. Clean any dirt and corrosion from the bore of the arm, and file off any sharp edges.
4. Fit the polyurethane part A into the arm, with the smaller diameter facing the outer face of the arm, as shown in figure 1.
5. Push two polyurethane B parts into the polyurethane A part, one from each side.
6. Apply some of the supplied grease to the bore of the polyurethane parts and push in the stainless steel sleeve.
7. Fit the rear trailing arm back to the car and tension all hardware to manufacturers recommended torque settings.

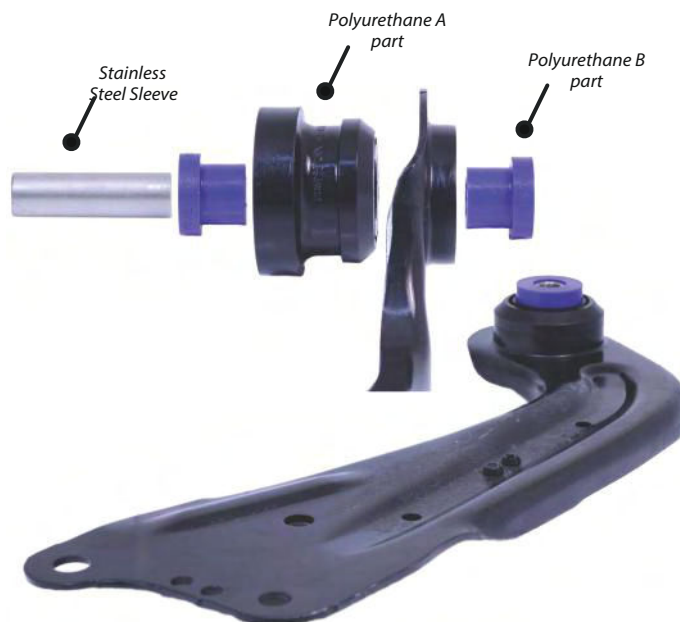

Figure 1

POWERFLEX®

PART NUMBER

PFF85-832

DESCRIPTION

LOWER ENGINE MOUNT INSERT

INSTALLATION GUIDE

Contents (parts per pack):

- | | |
|-----------------------|--------------------------|
| 1 x Polyurethane Bush | 1 x PTFE Silicone Grease |
| 1 x Metal Outer Shell | 1 x Metal Washer |

Please read the complete fitting instructions and check package components before fitment. These fitting instructions are to be used as a guide and in conjunction with workshop manual.

It is recommended that:

- all work to be carried out by a licensed technician;
- all safety precautions adhered to;
- wheel alignment to be checked and adjusted as required after any suspension work.
- All fasteners must be tensioned to manufacturer's torque settings.



Use PFF85-832 Or PFF85-833 For OEM part number 5Q0196 037 B



Fitting Instructions:

1. Access the lower engine mount which is located in the front sub frame under the car.
2. Remove the bolt from the lower engine mount.

Note: the manufacturer's bolts are stretch bolts and new bolts are recommended on re-fit.

3. The insert pushes into the voids of the original bush. Remove any flash lines and clean the dirt from the voidings.
4. Slide the new PU insert into the voids of the rubber bush, as shown in Figure 1.
5. Position the supplied washer on top of the PU insert. Push the supplied sleeve into the bore of the washer, as shown in Figure 1.
6. Use the original bolt and small washer to secure the PU insert kit into the rubber engine mount, as shown in Figure 1.
7. Tension all hardware to manufacturers recommended torque settings.



Figure 1 - assembly of PFF85-832 in the engine mount